

FUEL OIL FLOW DIAGRAM - PART A

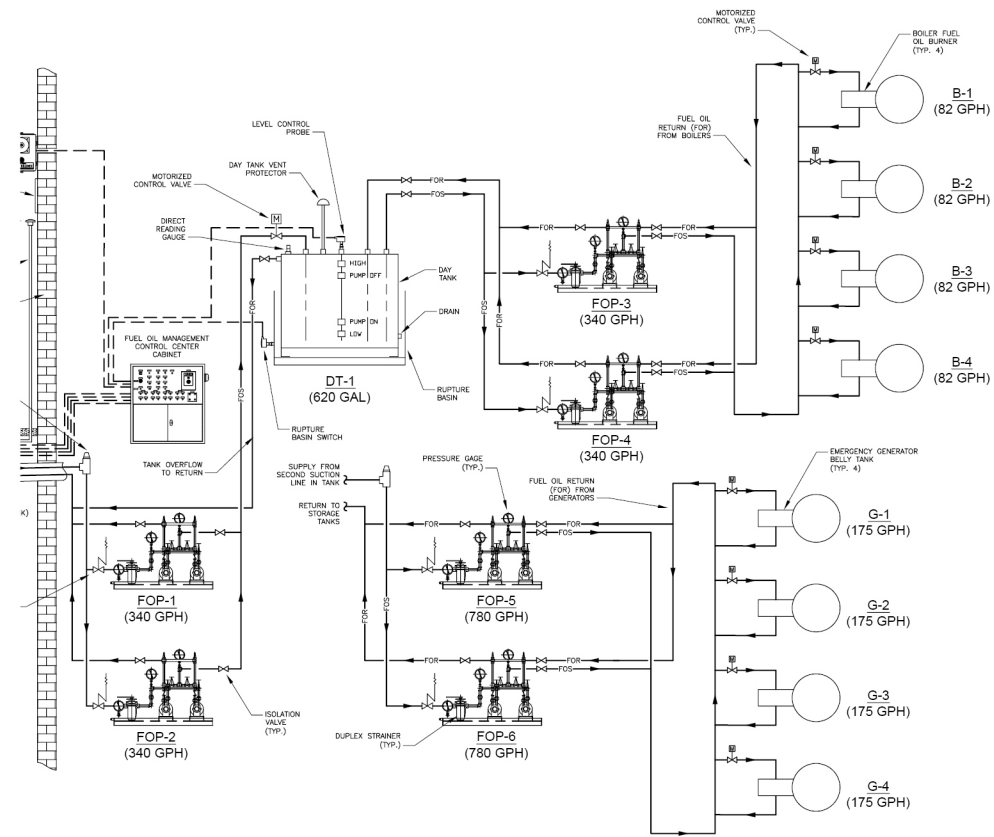

FUEL OIL FLOW DIAGRAM - PART B

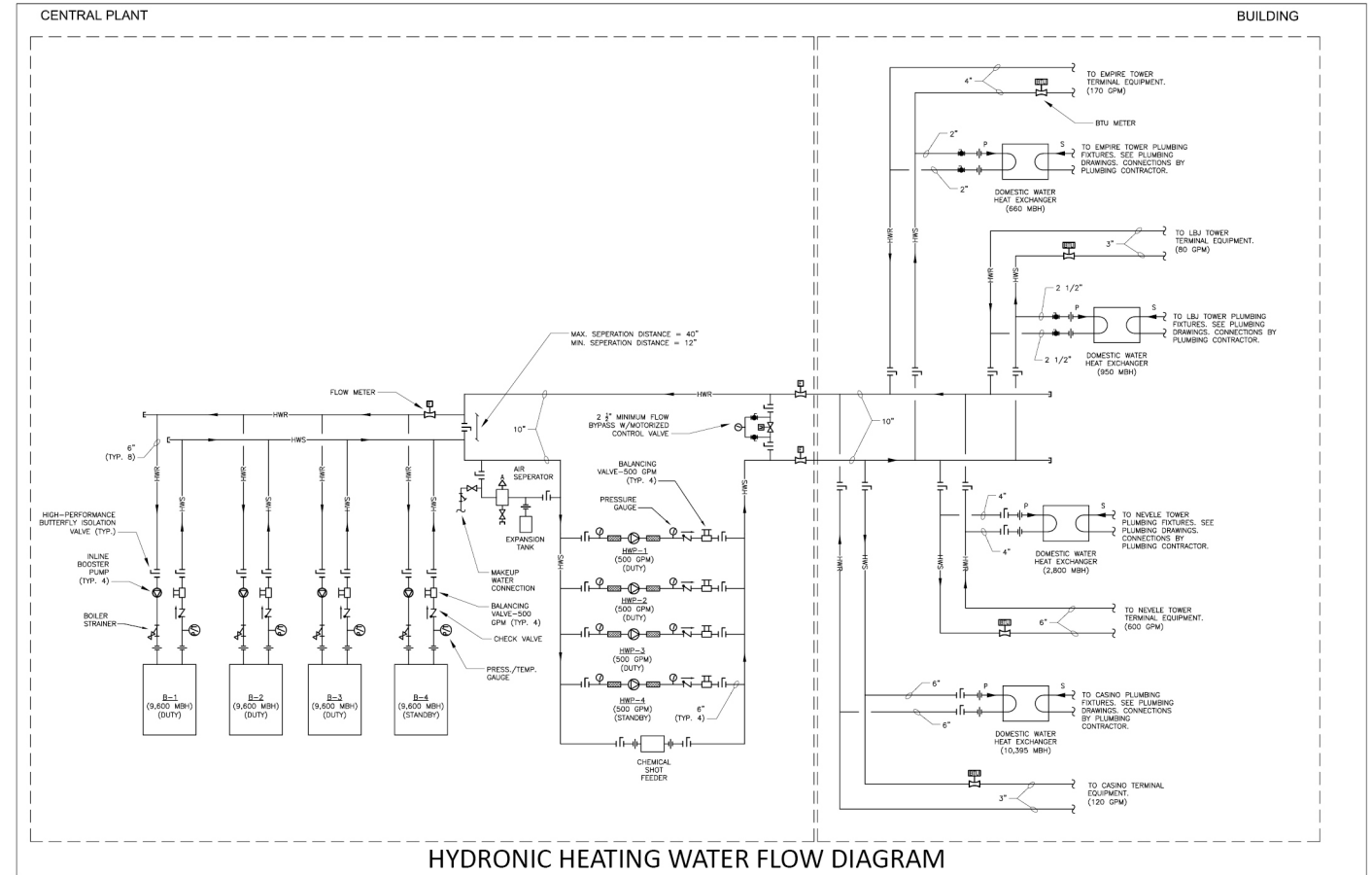

HYDRONIC HEATING WATER FLOW DIAGRAM

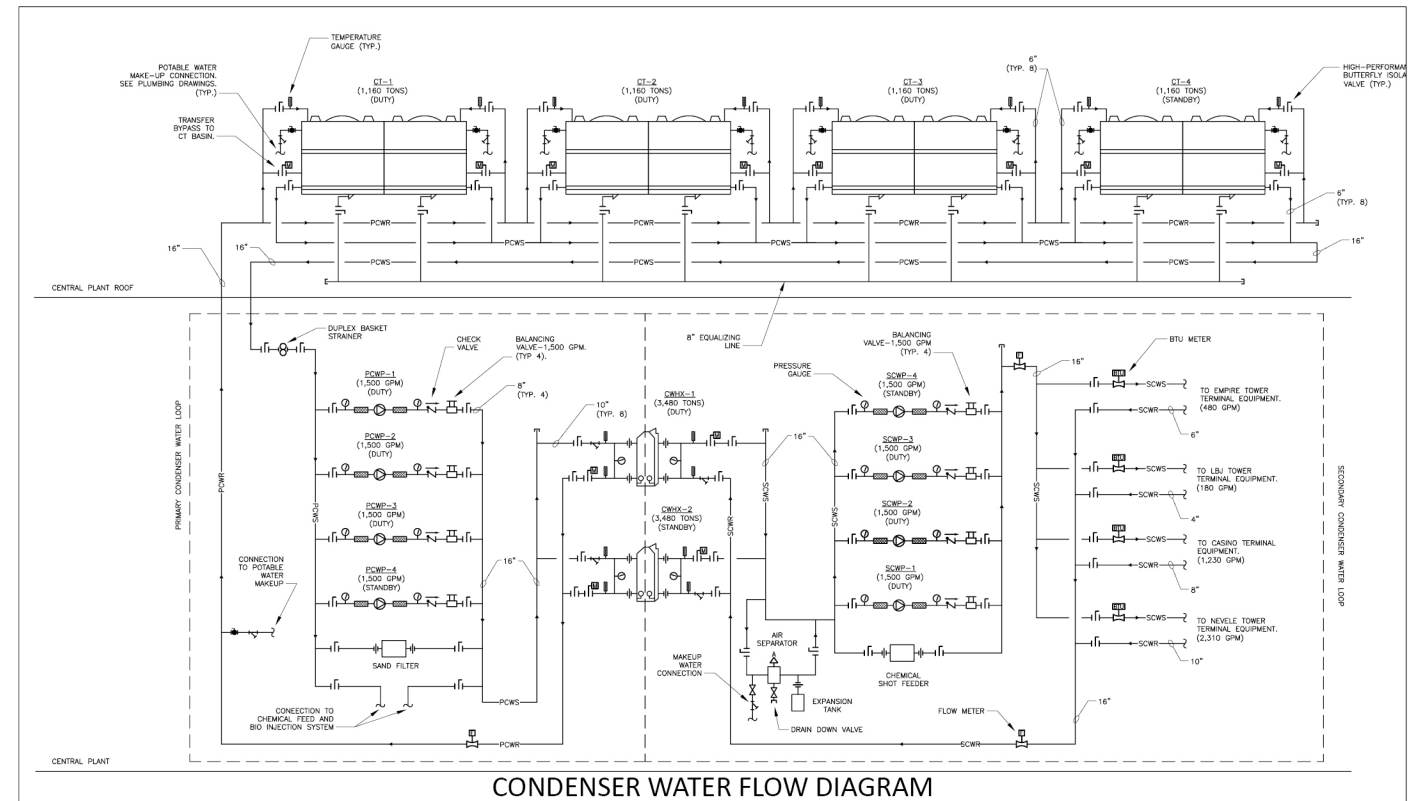

CONDENSER WATER FLOW DIAGRAM

MECHANICAL SINGLE-LINE DIAGRAMS